

G2 SEAL AND MACHINE ROTARY LIP SEAL CATALOG



WWW.G2SEAL.COM
GREG@G2SEAL.COM

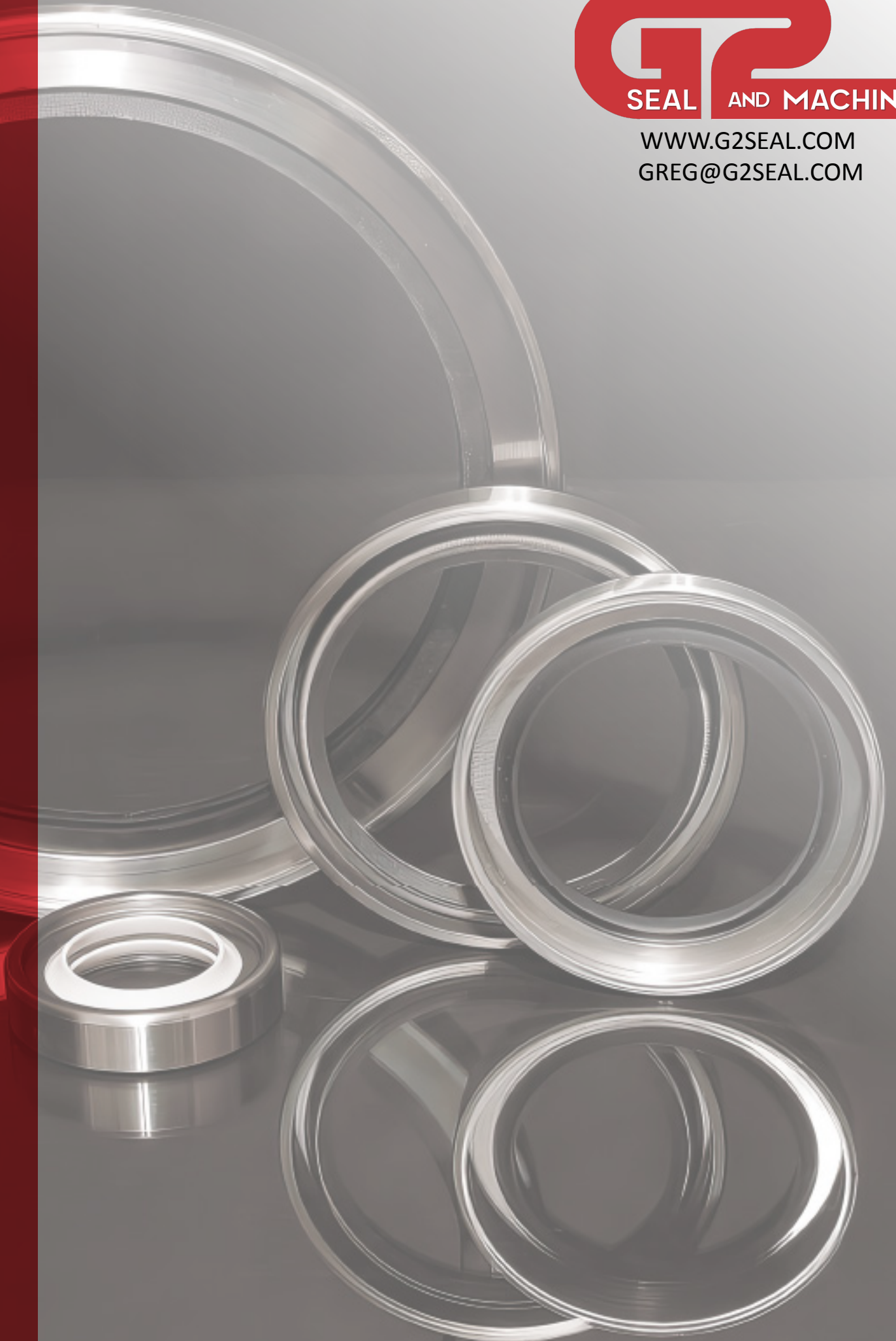

TABLE OF CONTENTS

About Us.....	2	Part Numbering System	7, 8
Anatomy of a Rotary Lip Seal	3	Dash # Designations	9, 10
Metal Cased Lip Seal Series.....	4	Hardware Design	11
Polymer Lip Seals.....	5	Application Data Sheet.....	12
Lip Materials.....	6		

ABOUT US

Founded in 2012, G2 Seal and Machine has been manufacturing high performance PTFE Rotary Lip Seals for over 10 years. With over 30 years in the PTFE Rotary Seal manufacturing. Our knowledge was passed down from engineers in the field that pioneered the market, specializing in difficult applications combining temperature extremes, high speeds, corrosive fluids or high pressures, we do our best to provide the best seal for your application.

We are located in Leesville, South Carolina. Our 14,000 sq ft plant is where we design and manufacture our high-speed rotary seals along with other machined polymer parts. At this facility we specialize in metal cased and all polymer lip seals. All manufacturing of these seals is performed in house using our proprietary design and manufacturing processes. The equipment we use includes:

- HAAS CNC lathes for cutting PTFE elements
- Manual lathes for roll forming
- Punch press for punching out metal blanks & holes
- Metal circle cutters
- Metal shears
- Manual mills
- Laser marking machine
- QC equipment & gages
- Metal band saws, both vertical & horizontal
- Tool grinders



With this equipment we can produce metal cased seals in aluminum, cold rolled steel and stainless steels, 304 and 316. Other more exotic case materials are available upon request. Contact G2 Seal engineering for specific materials. Currently, sizes for our metal cased lip seals range from a maximum O.D. of about 20" to a minimum I.D. of 0.3". Various cross sections and widths are available in each size.

As an alternative to the metal cased lip seals, we offer our polymer lip seal line of non-metallic rotary lip seals. Polymer lip seals are machined from a base polymer, usually PTFE and instead of a metal case, they use an o-ring to seal on the O.D. This type of seal is easier to install and remove but requires additional gland design consideration to be effective.

Polymer lip seal sizes range from about 20" O.D. to 0.09" I.D. with custom widths and cross sections available.



ANATOMY OF A ROTARY LIP SEAL

Rotary lip seals are designed to handle a wide range of applications. Generally, they are best suited for high-speed / low-pressure service. Speeds up to 8000 SFPM and pressures up to 250 psi are typical ranges for these types of seals.

To achieve sealing under these conditions, the seals are made up of several components. The drawings below define an example components of metal cased and polymer lip seals.

Metal Cased Lip Seal

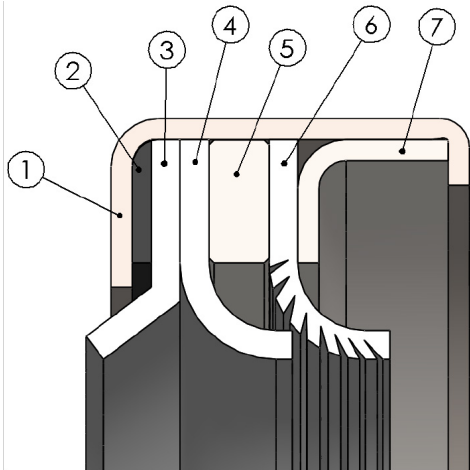

1. Metal Case
2. Gasket
3. Wiper Lip
4. PTFE Lip
5. Metal Spacer
6. Hydrodynamic Lip
7. Metal Spacer





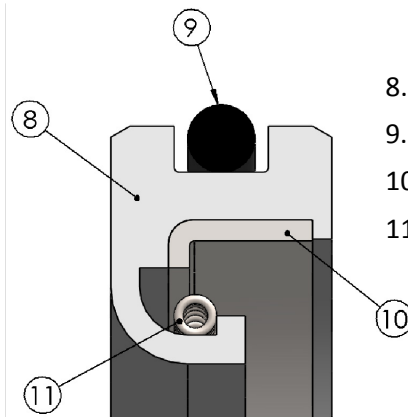





Polymer Lip Seal











8. Seal Jacket
9. O-Ring
10. Metal Support Ring
11. Garter Spring

METAL CASED LIP SEAL SERIES

CROSS SECTION	SERIES	RECOMMENDED SEAL WIDTH (see pages 9 & 10)	DESCRIPTION
	1101-A	Narrow	Standard single lip - A good general purpose seal for a wide variety of applications. Pressures to 250 psi and temperatures 550°F.
	1301-A	Medium	Standard lip & wiper seal - The addition of a wiper helps keep the seal area free of environmental contaminants.
	1101-G	Narrow	Single elf shoe lip - The "elf shoe design adds extra sealing force at the point of contact. Higher wear rates can result.
	1301-G	Medium	Single elf shoe lip & wiper - The elf shoe plus wiper configuration is great for tight sealing in rugged environments.
	1101-B	Narrow	Single directional hydro lip (clockwise or counter clockwise related to shaft rotation) - A spiral groove in the sealing lip pumps fluid away from the seal chamber.
	1301-B	Medium	Hydro lip & wiper (clockwise or counter clockwise) - Same as the 1101-B, but with the added benefit of a wiper.
	1101-D	Narrow	Single pre-spun lip - Provides a more precise and predictable contact area and load. Good for low friction requirements.
	1301-D	Medium	Pre-Spun lip & wiper - Same as 1101-D but with the added benefit of a wiper.
	1101-H	Narrow	Single lip with garter spring - For use in situations of runnout and eccentricity. The garter spring provides additional sealing force to keep the lip in contact with the shaft.
	1301-H	Medium	Single lip with garter spring & wiper - Same as 1101-H but with the added benefit of a wiper.
	1201-A	Wide	Two standard lips - Provides redundant sealing and additional seal life in critical sealing applications.
	1401-A	Wide	Two standard lips & wiper - Same as 1201-A but with the added benefit of a wiper.
	1201-AB	Wide	Standard lip & hydro lip (clockwise or counter clockwise) - Sprial groove provides puming action backed up by a standard lip for redunancy. Shaft rotation is needed for appication.
	1401-AB	Wide	Standard lip & hydro lip (clockwise or counter clockwise) with wiper Same as 1201-AB but with the added benefit of a wiper.

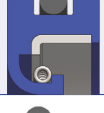
POLYMER LIP SEALS

CROSS SECTION	SERIES	RECOMMENDED SEAL WIDTH (see pages 9 & 10)	DESCRIPTION
	420	Narrow	Standard lip / Normal Temperatures - An all polymer version of the standard 450 series seal. Can be split for installation into solid glands for non critical service.
	430	Narrow	Standard lip / Extreme Temperatures* - Reinforced with a metal support ring, the extreme temperature design can be used up to 500° F.
	421	Narrow	Elf Shoe Lip / Normal Temperatures - The elf shoe lip design creates additional radial load for tighter sealing.
	431	Narrow	Elf Shoe Lip / Extreme Temperatures* - The elf shoe plus extreme temperature is an excellent choice for difficult combinations of temperature, pressure and speed.
	422	Narrow	Machined Lip / Normal Temperatures - Gives precise control of contact force and point of contact in friction sensitive applications.
	432	Narrow	Machined Lip / Extreme Temperatures* - Great for large diameter and/or high temperature applications
	423	Narrow	Garter Spring Lip / Normal Temperatures - For situations of run-out and eccentricity, the garter spring helps keep the sealing lip in contact with the shaft while static or rotating.
	433	Narrow	Garter Spring Lip / Extreme Temperatures* - Same as 423 but best suited for high temperatures or large diameters.
	424	Narrow	Double Lip / Normal Temperatures - Provides redundant sealing contact points for minimum leakage and long life. Maximum PV 200,000 lubricated, 50,500 non-lubricated.

** Extreme temperature designs should also be used with polymer seals larger than 4-1/2" in diameter. Consult factory when specifying extreme temperature designs.*

** Unless otherwise noted, maximum PV 75,000 lubricated, 37,500 non-lubricated.*



MATERIAL CODE	DESCRIPTION	TEMPERATURE RANGE (°F)	APPLICATION
01	Virgin PTFE	-425 / +450	FDA approved material for use in static and slow dynamic applications.
02	Carbon/Graphite PTFE - Low Fill	-320 / +475	Good wear resistance in low lubricity fluids.
03	Glass Filled PTFE	-250 / +550	Excellent electrical properties and a low coefficient of friction.
04	Polyimide Filled PTFE	-400 / +550	A non-abrasive polymer and a good choice for applications involving softer mating surfaces like aluminum or other plastics.
05	Glass/Moly PTFE - High Fill	-200 / +575	Highly wear resistant in high-speed applications. Best used on hardened, smooth shafts.
06	UHMW-PE	-320 / +200	Excellent wear and abrasion resistance in water based media.
07	Ekonol Filled PTFE	-200 / +550	Great for running against softer metal shafts and in high-temperature environments.
08	Graphite Filled PTFE	-250 / +550	A high-speed material used in poorly lubricated services.
09	Carbon/Graphite PTFE – High Fill	-200 / +550	Increased wear resistance compared to 02 material with additional filler.
10	Moly Filled PTFE	-320 / +500	Light duty material excellent in dry gas service.
11	Glass/Moly – Low Fill	-275 / +500	Same as 05 material but will lower fill percentage. For lighter duty services.
12	Thermoplastic Elastomer	-80 / +275	A very tight sealing material with good wear resistance, as well as low temperature and corrosion resistance.
13	Carbon/Ryton Filled PTFE	-200 / +550	Polymer reinforced compound for difficult combinations of temperature and pressure
14	ETFE - Tefzel™	-100 / +300	High resistance to radiation. Consult factory before specifying.

* Unless otherwise noted, maximum PV 75,000 lubricated, 37,500 non-lubricated.

PART NUMBERING SYSTEM

Many applications are sized for industry standard glands and when sending in a RFQ the numbering system below is an effective way to communicate your application needs. If you do not see the seal in the descriptions we can still make your seal, communicate your needs and we will ask questions as needed. For custom sizes, contact G2 Seal and Machine.

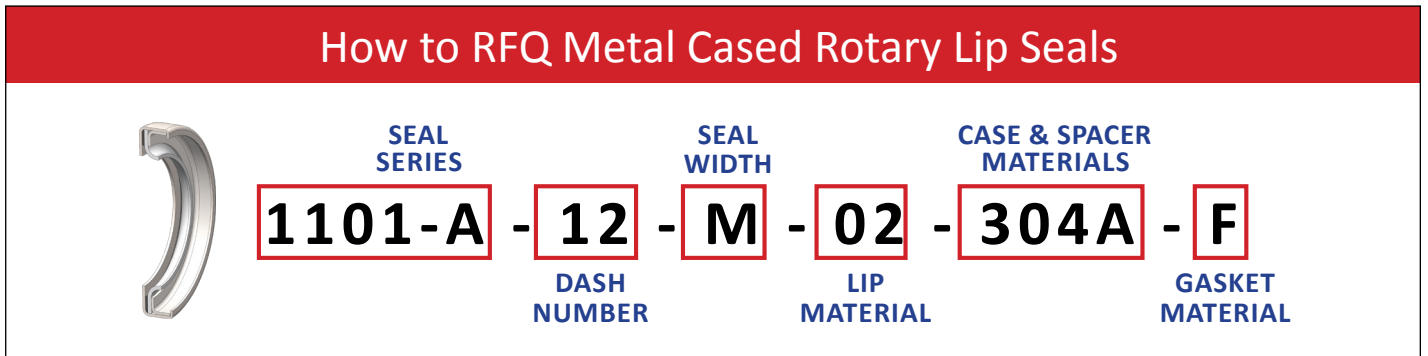

SEAL SERIES

1101-1401 = (see page 4)

DASH NUMBER

01-135 = (see pages 9 & 10)

SEAL WIDTH

N = Narrow

M = Medium (see pages 9 & 10)

W = Wide

LIP MATERIAL

01-14 = (see page 6)

CASE & SPACER MATERIALS

CASE

304 = 304 Stainless Steel

316 = 316 Stainless Steel

LCS = Low Carbon Steel

A = Aluminum

X = Custom

SPACER

4 = 304 Stainless Steel

6 = 316 Stainless Steel

L = Low Carbon Steel

A = Aluminum

X = Custom

GASKET MATERIAL

F = Fluorocarbon Elastomer (FKM)

N = Nitrile

X = Custom



How to Order Polymer Lip Seals



SEAL SERIES

420-433 = (see page 5)

DASH NUMBER

01-135 = (see pages 9 & 10)

SEAL WIDTH

N = Narrow

M = Medium (see pages 9 & 10)

W = Wide

LIP MATERIAL

01-14 = (see page 6)

SUPPORT RING MATERIAL

304 = 304 Stainless Steel

316 = 316 Stainless Steel

LCS = Low Carbon Steel

A = Aluminum

N = No Support Ring

O-RING MATERIAL

F = Fluorocarbon Elastomer (FKM)

N = Nitrile

X = Custom

GARTER SPRING MATERIAL

304 = 304 Stainless Steel

316 = 316 Stainless Steel

N = No Garter Spring



DASH # DESIGNATIONS

DASH #	SHAFT Ø	BORE Ø	SEAL WIDTH			DASH #	SHAFT Ø	BORE Ø	SEAL WIDTH		
			NARROW (N)	MEDIUM (M)	WIDE (W)				NARROW (N)	MEDIUM (M)	WIDE (W)
01	0.500	0.999	0.250	0.313	0.375	36	1.625	2.250	0.313	0.375	0.438
02	0.500	1.124	0.250	0.313	0.375	37	1.625	2.374	0.313	0.375	0.438
03	0.500	1.250	0.250	0.313	0.375	38	1.625	2.502	0.313	0.375	0.438
04	0.625	1.124	0.250	0.313	0.375	39	1.625	2.623	0.313	0.375	0.438
05	0.625	1.250	0.250	0.313	0.375	40	1.750	2.374	0.313	0.375	0.438
06	0.625	1.375	0.250	0.313	0.375	41	1.750	2.502	0.313	0.375	0.438
07	0.625	1.499	0.250	0.313	0.375	42	1.750	2.623	0.313	0.375	0.438
08	0.750	1.250	0.250	0.313	0.375	43	1.750	2.750	0.313	0.375	0.438
09	0.750	1.375	0.250	0.313	0.375	44	2.000	2.623	0.375	0.437	0.500
10	0.750	1.499	0.250	0.313	0.375	45	2.000	2.750	0.375	0.437	0.500
11	0.750	1.624	0.250	0.313	0.375	46	2.000	2.875	0.375	0.437	0.500
12	0.875	1.375	0.250	0.313	0.375	47	2.000	3.000	0.375	0.437	0.500
13	0.875	1.499	0.250	0.313	0.375	48	2.000	3.125	0.375	0.437	0.500
14	0.875	1.624	0.250	0.313	0.375	49	2.125	2.750	0.375	0.437	0.500
15	0.875	1.752	0.250	0.313	0.375	50	2.125	2.875	0.375	0.437	0.500
16	1.000	1.499	0.250	0.313	0.375	51	2.125	3.000	0.375	0.437	0.500
17	1.000	1.624	0.250	0.313	0.375	52	2.125	3.125	0.375	0.437	0.500
18	1.000	1.752	0.250	0.313	0.375	53	2.125	3.251	0.375	0.437	0.500
19	1.000	1.874	0.250	0.313	0.375	54	2.250	3.000	0.375	0.437	0.500
20	1.125	1.624	0.313	0.375	0.438	55	2.250	3.125	0.375	0.437	0.500
21	1.125	1.752	0.313	0.375	0.438	56	2.250	3.251	0.375	0.437	0.500
22	1.125	1.874	0.313	0.375	0.438	57	2.250	3.371	0.375	0.437	0.500
23	1.125	2.000	0.313	0.375	0.438	58	2.375	3.125	0.375	0.437	0.500
24	1.125	1.752	0.313	0.375	0.438	59	2.375	3.251	0.375	0.437	0.500
25	1.125	1.874	0.313	0.375	0.438	60	2.375	3.371	0.375	0.437	0.500
26	1.125	2.000	0.313	0.375	0.438	61	2.375	3.500	0.375	0.437	0.500
27	1.125	2.125	0.313	0.375	0.438	62	2.500	3.251	0.375	0.437	0.500
28	1.375	2.000	0.313	0.375	0.438	63	2.500	3.371	0.375	0.437	0.500
29	1.375	2.125	0.313	0.375	0.438	64	2.500	3.500	0.375	0.437	0.500
30	1.375	2.250	0.313	0.375	0.438	65	2.500	3.623	0.375	0.437	0.500
31	1.375	2.374	0.313	0.375	0.438	66	2.625	3.371	0.375	0.437	0.500
32	1.500	2.125	0.313	0.375	0.438	67	2.625	3.500	0.375	0.437	0.500
33	1.500	2.250	0.313	0.375	0.438	68	2.625	3.623	0.375	0.437	0.500
34	1.500	2.374	0.313	0.375	0.438	69	2.625	3.751	0.375	0.437	0.500
35	1.500	2.502	0.313	0.375	0.438	70	2.750	3.500	0.375	0.437	0.500

[CONTINUED] **DASH # DESIGNATIONS**

DASH Ø	SHAFT #	BORE Ø	SEAL WIDTH		
			NARROW (N)	MEDIUM (M)	WIDE (W)
71	2.750	3.623	0.375	0.437	0.500
72	2.750	3.751	0.375	0.437	0.500
73	2.750	3.875	0.375	0.437	0.500
74	2.875	3.623	0.375	0.437	0.500
75	2.875	3.751	0.375	0.437	0.500
76	2.875	3.875	0.375	0.437	0.500
77	2.875	4.003	0.375	0.437	0.500
78	3.000	3.751	0.375	0.437	0.500
79	3.000	3.875	0.375	0.437	0.500
80	3.000	4.003	0.375	0.437	0.500
81	3.000	4.125	0.375	0.437	0.500
82	3.125	4.125	0.375	0.437	0.500
83	3.125	4.249	0.375	0.437	0.500
84	3.125	4.376	0.375	0.437	0.500
85	3.125	4.500	0.375	0.437	0.500
86	3.250	4.249	0.375	0.437	0.500
87	3.250	4.376	0.375	0.437	0.500
88	3.250	4.500	0.375	0.437	0.500
89	3.250	4.626	0.375	0.437	0.500
90	3.375	4.249	0.375	0.437	0.500
91	3.375	4.376	0.375	0.437	0.500
92	3.375	4.500	0.375	0.437	0.500
93	3.375	4.626	0.375	0.437	0.500
94	3.500	4.376	0.437	0.500	0.625
95	3.500	4.500	0.437	0.500	0.625
96	3.500	4.626	0.437	0.500	0.625
97	3.500	4.751	0.437	0.500	0.625
98	3.625	4.626	0.437	0.500	0.625
99	3.625	4.751	0.437	0.500	0.625
100	3.625	4.876	0.437	0.500	0.625
101	3.625	4.999	0.437	0.500	0.625
102	3.875	4.876	0.437	0.500	0.625
103	3.875	4.999	0.437	0.500	0.625
104	3.875	5.125	0.437	0.500	0.625
105	3.875	5.251	0.437	0.500	0.625

DASH #	SHAFT Ø	BORE Ø	SEAL WIDTH		
			NARROW (N)	MEDIUM (M)	WIDE (W)
106	4.000	4.999	0.437	0.500	0.625
107	4.000	5.125	0.437	0.500	0.625
108	4.000	5.251	0.437	0.500	0.625
109	4.000	5.375	0.437	0.500	0.625
110	4.250	5.251	0.437	0.500	0.625
111	4.250	5.375	0.437	0.500	0.625
112	4.250	5.501	0.437	0.500	0.625
113	4.250	5.625	0.437	0.500	0.625
114	4.500	5.501	0.437	0.500	0.625
115	4.500	5.625	0.437	0.500	0.625
116	4.500	5.751	0.437	0.500	0.625
117	4.750	5.751	0.437	0.500	0.625
118	4.750	6.000	0.437	0.500	0.625
119	5.000	6.000	0.500	0.625	0.750
120	5.000	6.250	0.500	0.625	0.750
121	5.000	6.375	0.500	0.625	0.750
122	5.250	6.250	0.500	0.625	0.750
123	5.250	6.375	0.500	0.625	0.750
124	5.250	6.500	0.500	0.625	0.750
125	5.250	6.625	0.500	0.625	0.750
126	5.500	6.500	0.500	0.625	0.750
127	5.500	6.625	0.500	0.625	0.750
128	5.500	6.750	0.500	0.625	0.750
129	5.500	6.875	0.500	0.625	0.750
130	5.750	6.750	0.500	0.625	0.750
131	5.750	6.875	0.500	0.625	0.750
132	5.750	7.000	0.500	0.625	0.750
133	5.750	7.125	0.500	0.625	0.750
134	6.000	7.125	0.500	0.625	0.750
135	6.000	7.500	0.500	0.625	0.750

* Dash #'s based on RMA oil seal standard sizes.
Contact G2 Seal Engineering for custom sizes.

HARDWARE DESIGN

Gland design is one of the most critical considerations for successful sealing. Most seals are designed around the gland dimensions to ensure proper fit and contact forces. The gland dimensions, tolerances, surface finish and hardness all contribute to the success (or failure) of any sealing system. Below are some gland definitions and general guidelines for hardware preparation.

METAL CASED LIP SEAL POLYMER LIP SEAL GLAND DESIGN GLAND DESIGN

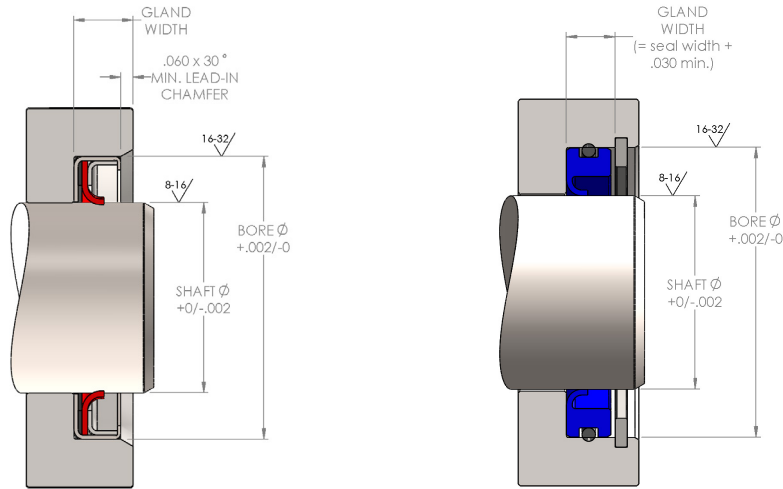

PRESSURE — VELOCITY OR P-V LIMIT

Also very important to consider when choosing which seal to use is the combination of system pressure and shaft velocity. Rotary lip seals are designed for high speeds but not necessarily high pressures. The graph below can help determine if your application is suitable for a rotary lip seal.

P-V LIMIT FOR FORMED LIP SEALS

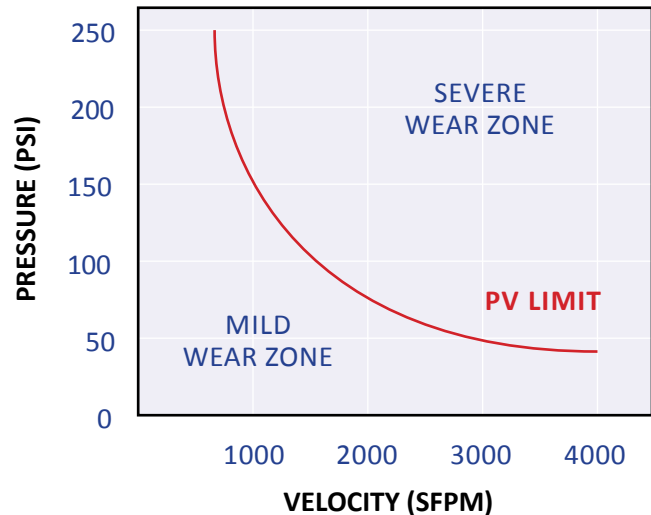

$$PV = (\text{system pressure} \times \text{surface velocity in SFPM})$$

APPLICATION DATA SHEET

CUSTOMER INFORMATION

COMPANY NAME:	CONTACT NAME:		
STREET ADDRESS:	CITY:	STATE: ZIP CODE:	
EMAIL ADDRESS:	PHONE NUMBER:		

APPLICATION DATA

SHAFT Ø:	BORE Ø:	GLAND WIDTH:	SPEED (RPM):
TOLERANCE:	TOLERANCE:	TOLERANCE:	
SYSTEM PRESSURE—	TEMPERATURE—	MEDIA TO BE SEALED:	
MIN:	MIN:		
OPERATING:	OPERATING:	DIRECTION OF SHAFT ROTATION (AS VIEWED FROM PRESSURE SIDE): ☐ ☐	
MAX:	MAX:		

SKETCH / ADDITIONAL INFORMATION

G2 Seal and Machine
High-Speed Rotary Lip seals

6501 Augusta Highway, Leesville, SC 29070

P: 989-627-1989 | greg@g2seal.com



WWW.G2SEAL.COM